

DH-CA-DBW581B

700TVL Day/Night WDR Vandal-proof Dome Camera



Features

- > 1/3" SONY Super HAD CCD II & Effio-P DSP
- > High resolution of 700TVL(Color)
- > WDR, Day/Night(ICR), DNR (2D&3D), Auto iris, AWB, AGC,BLC, MD, DZOOM, DIS, Privacy Masking, Picture Adjustment
- > 2.8~12mm varifocal lens
- > IR LEDs length 30m, Smart IR
- > OSD, IP66, IK10, DC12V (-A model: DC12V/AC24V dual power supply)

DH-CA-DBW581B

Technical Specifications

Model		DH-CA-DBW581BP(-A)	DH-CA-DBW581BN(-A)
Camera			
Image Sensor		1/3" Super HAD CCD II	
Effective Pixels		976(H) x 582(V), 570K pixels	976(H) x 494(V), 480K pixels
Horizontal Resolution		Color: 700TVL	
Electronic Shutter	Auto	1/50s~1/100,000s, 10s~1/100,000s@Slow shutter, 512x	1/60s~1/100,000, 8s~1/100,000s@Slow shutter, 512x
	Manual	1/50s,1/120s,1/250s,1/500s,1/1000s,1/2000s,1/4000s,1/10,000s	1/60s,1/100s,1/250s,1/500s,1/1000s,1/2000s,1/4000s,1/10,000s
Synchronization		Internal / External	
Min. Illumination		Color: 0.005Lux@F1.4, 0.0005Lux@F1.4(Slow shutter, 512x)	
		B/W: 0.0005Lux@F1.4, 0.00005Lux@F1.4(Slow shutter, 512x)	
S/N Ratio		>65dB	
Video Output		1Vp-p Composite Output (75Ω/BNC)	
Camera Features			
Max. IR Length		30m, Smart IR	
OSD		English, Chinese	
Day/Night		Auto (ICR) / Color / B/W	
Backlight Compensation		BLC / HLC / WDR (75dB)	
White Balance		AWB/AWB LOCK/CUSTOM 1/CUSTOM 2/ANTI CR CNT/MANUAL/ATW	
Gain Control		Auto / Manual	
Noise Reduction		2D / 3D	
Privacy Masking		Up to 15 areas	
Digital Zoom		Magnitude / Horizontal / Vertical	
Picture Adjustment		Mirror / Brightness / Contrast / Sharpness / Hue / Gain / Slow Shutter	
Lens			
Focal Length		2.8~12mm optional	
Focus Control		Manual	
Lens Type		Manual / Auto iris	
Mount Type		Φ14	
General			
Power Supply		DC12V±10% (-A model: DC12V/AC24V dual power supply)	
Power Consumption		Max 4W	
Working Environment		-30°C~+60°C / 20%~80%RH	
Protection Level		IK10 & IP66	
Dimensions		Φ160mm×118.5mm	
Weight		980g (-A: 1000g)	

DH-CA-DBW581B

Dimensions (mm)

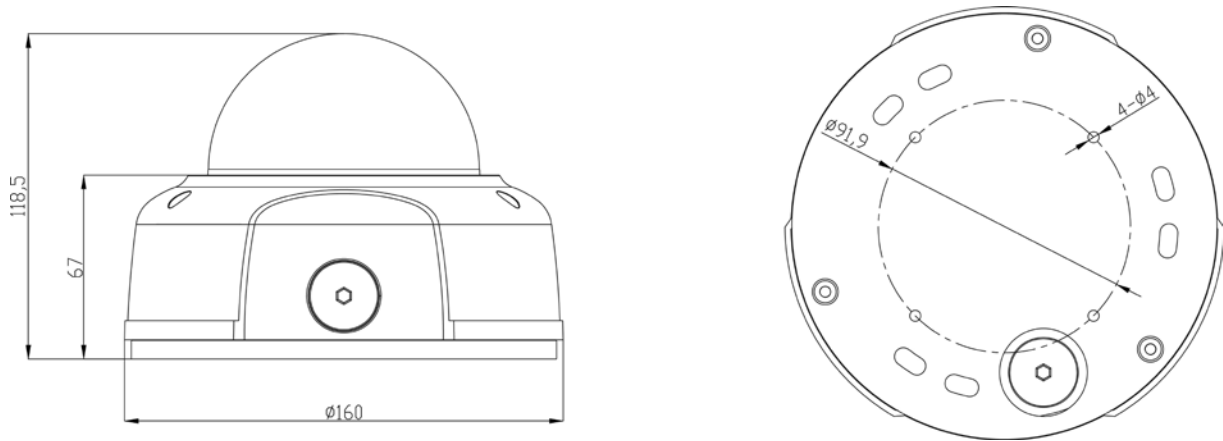

Dahua Technology Co., Ltd. 1187BinAn Road, Binjiang District, Hangzhou, China
Tel: 66956096-09126017817-09107616575
email:imensazaa@gmail.com
www.irandahua.com